

CAT-iq Module for IAD applications

Based on SC14CVM480FL or CV14CVM488R and CAT-iq software (SW)

The CAT-iq (Cordless Advanced Technology - internet and quality) V2.0 module for IAD (Integrated Access Device) applications is an efficient and high quality solution for easy integration of wideband cordless telephony into network equipment like gateways/routers and cable modems, hence providing an easy path to IAD based wideband cordless telephony.



The module is based on the new CAT-iq standard, which builds upon the well proven DECT technology. The module provides superior voice quality through the application of wideband audio (G.722) along with basic telephony features.

Interoperability and backwards compatibility with legacy DECT GAP equipment is ensured through the CAT-iq certification program. The CAT-iq Module implements the CAT-iq V2.0-profile (wideband audio, basic interoperability).

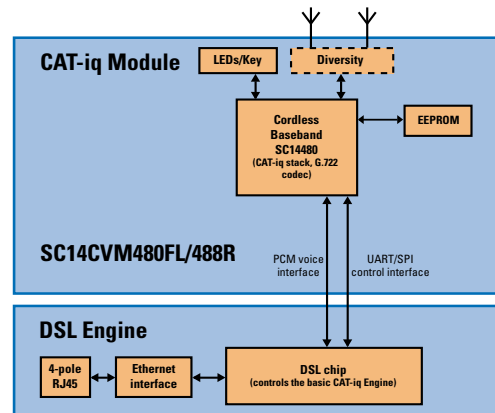

Example: CAT-iq Module integrated into a cable modem

The software includes FirmWare Upgrade (FWU). Proprietary "Software Upgrade Over The Air" (SUOTA) is implemented in order to support cordless FWU to the Portable Part (PP). FWU and SUOTA makes it possible to upgrade a complete FP + PP system to the latest features of the DECT Forum CAT-iq roadmap.

CAT-iq V2.0

The module is the perfect tool for the integration of DECT into IAD routers and modems while the CAT-iq SW roadmap is in development. It saves R&D cost, provides a fast time to market and the CAT-iq roadmap can smoothly be followed by FWU's.

The implementation of CAT-iq V2.0 requires that most of the DECT functionalities need to be controlled by the IAD host processor. This requirement off-loads the module capacity needs. It therefore offers the possibility to use a cost saving RAM based processor for the module.

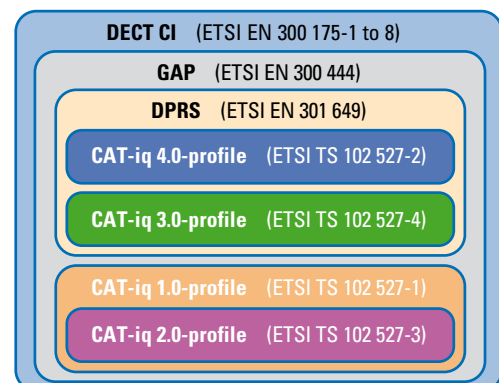

CAT-iq profiles as defined by the ETSI

Technical specifications

Technical characteristics SC14CVM480FL/488R

- Wideband audio (G.722) – max. 4 simultaneous wideband calls
- Four 8 kHz or 16kHz 16 bit linear PCM channels
- Compliant to ETSI EN 300 444 (GAP), ETSI EN 300 175-1 to 8 (DECT CI), and ETSI TS 102 527-1 (CAT-iq 2.0-profile)
- Max. 6 registered handsets
- Receiver sensitivity: -95 dBm (typ.) at a BER equal to 0.001
- Transmit power: +25 dBm (typ.)
- Receiver IIP3: -26 dBm (typ.)
- Low power consumption: 4.5 mA (typ.) standby, 50 mA (typ.) active
- Modulation: GFSK, BW 20 dB <864 kHz
- 1880-1900 MHz band, 10 carriers with 6 wideband duplex channels per carrier
- Receiver filter against WLAN

General information

- Physical dimensions: 42 mm (Length), 37 mm (width), 5 mm (height)
- Module is controlled through UART or SPI interface

Supported codecs

PCM INTERFACE CODECS	AIR INTERFACE CODECS	
	G.722	G.726
16bit Linear PCM 8 kHz	-	+
16bit Linear PCM 16 kHz	+	-
G.711 a-law PCM 8 kHz	-	+
G.711 u-law PCM 8 kHz	-	+
CWB a-law PCM 8 kHz	+	-
CWB u-law PCM 8 kHz	+	-

IAD Development platform

Complete development platform to support designs based on PCM interfaces.

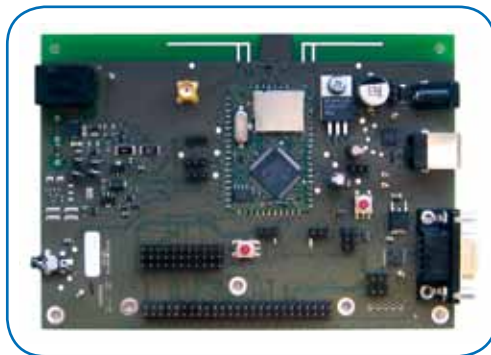

SC14480IADDEVKT

Clear benefits

- Easy integration of CAT-iq technology
- Builds upon proven DECT technology and adds superior voice quality through wideband audio
- Backwards compatibility ensures support for existing DECT GAP handsets
- CAT-iq is a Wi-Fi friendly technology – interference effects minimized due to separate allocated spectrum for CAT-iq
- DECT6.0 support

Design your own handsets?

SiTel offers the Natalie CAT-iq software stack. This is a complete, proven and scalable wireless protocol stack in C source code. All industry accepted protocols (DECT, DECT 6.0 and CAT-iq) are supported and a standard customizable MMI is provided for enabling fixed and portable part (FP/PP) functionality.

Possible ODM handsets?

Several ODM possibilities for basic and advanced CAT-iq handsets.



CAT-iq ODM sample handsets